

LED Grid Light GT20

LOW-CARBON LIGHTING

Drawings:

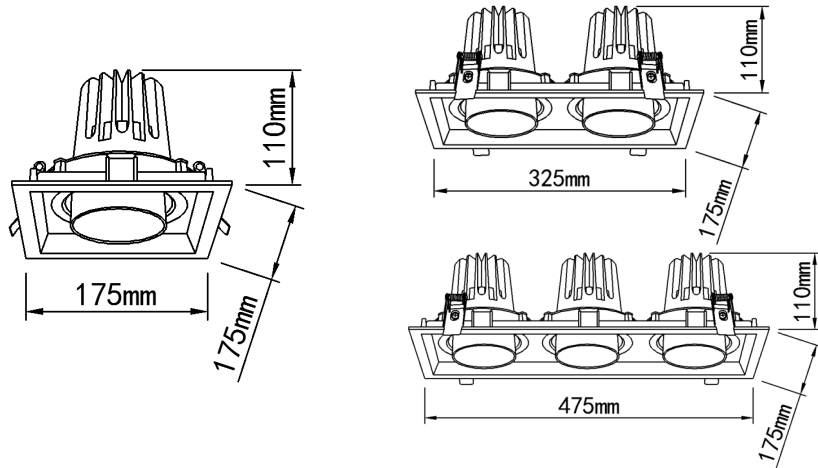

Model	Watt	Lumen	COB	Beam angle	Cutout
GT2001-25	25W	2000lm	Epistar	15°/24°	L160xW160mm
GT2002-50	2x25W	4000lm	Epistar	15°/24°	L305xW160mm
GT2003-75	3x25W	6000lm	Epistar	15°/24°	L465xW160mm

Features:

- Die-casting aluminum heat sink,
- Color temperature: 3000K, 4000K, 5000K,
- Direct connect to a AC200-240V (50~60Hz) supply
- Type of protection: IP20 (room side)
- Lifetime :L70/B70 up to 35,000 hrs
- Driver:BOKE
- LED:Epistar Chip,Ra80
- Dimmable:DALI/TRIAC/0-10V
- 5 years warranty



Light distribution curves

